

# C35 Control System User manual

NO : 86.A049

## Features :

- 3.5" LED Digital touch screen.
- Sound optical tips.
- Overload resistance relay 10A/5A
- Overload short-circuited protection, and 7-min automatic time lapse protection.
- Control the move forward, reverse and stop.
- Available to Work with KR06B by dot moving under.
- Normal working mode and suitable for blinds system.
- Standard 86X86 size.

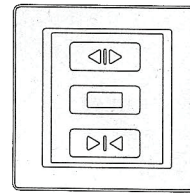

C35-1

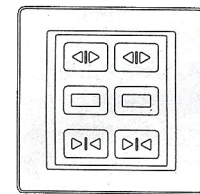

C35-2

## Specifications :

- Rated Voltage: ~~220~~<sup>110</sup>V/50HZ
- Rated Power: 300W
- Receiving sensitivity: -110dBm
- Receiving frequency: 433.92MHZ
- Working temperature: 0°C-75°C

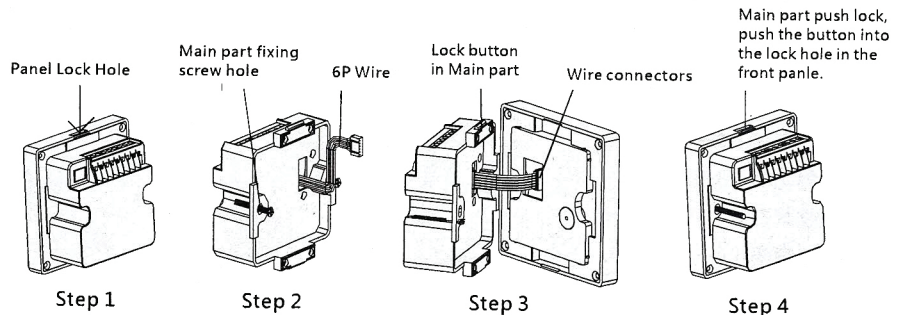

## Installing of receiving :

### Step 1:

Use one scew driver to separate front panel and the main part by releasing the push lock from lock hole in the front panel and open the front panel.

### Step 2:

Disconnect the 6P connectors wire, and tighen screws into the hole and fix the main part.

### Step 3:

As shown in the picture, connect 6P connector wire again and cover the front panel to the main part.

### Step 4:

Push lock buttons both in the top and bottom to the front panel lock holes, and the installing is completed.

## Wiring and connecting :

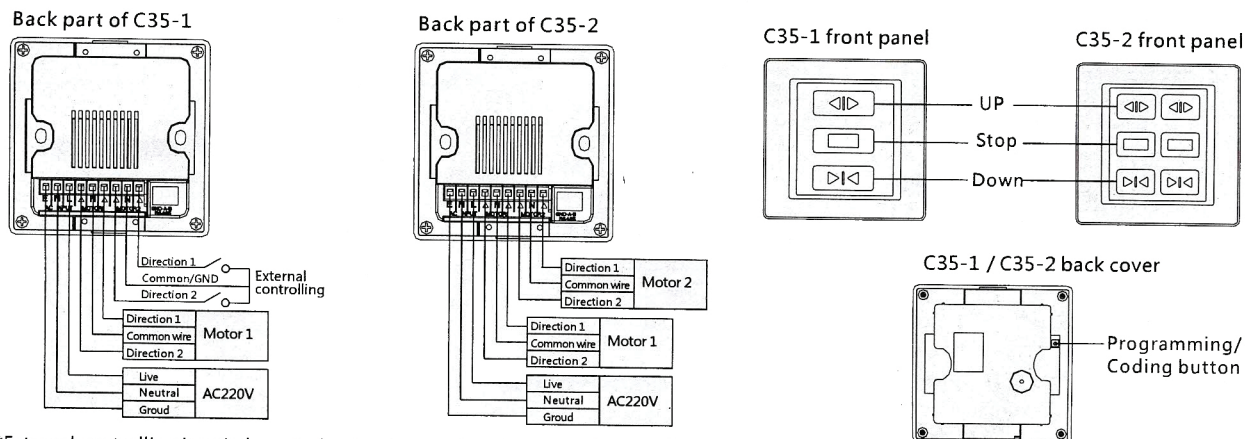

\*External controlling is switch control pulse signal, when the external controlling direction 1, direction 2 and common wire are all close, it is stop command.

## Programming / Coding of receiving :

### Coding:

- Keep Pressing the [coding button] for 5 seconds and the [stop button] flashes, and press the [stop button] and it keeps on.
- Select channel in the remote Contrl and then press the [up button] in the remote control, and the [stop button] in the receiving control flashes 3 times And goes off to tell the coding Operating is done.

### Clearing of coding

- Keep Pressing the [coding button] for 5 seconds and the [stop button] flashes, and press the [stop button] and it keeps on.
- And again keep pressing the [coding button] for 5 seconds and the [stop button] flashes 3 time and goes off to tell the clearing of coding operating is done.

### Reverse turning

- Keep Pressing the [coding button] for 5 seconds and the [stop button] flashes, and press the [stop button] and it keeps on.
- Press the [down button] in the receiving controller or [down button] in the remote control, the [stop button] in the receivingcontroller flashes 3 times And goes off to tell the operating of reserve turning is done.

### Dot move alternation

Keep press [up button] and the [stop button] 5 second simultaneously, and the [stop button] flashes 3 times and goes off to Tell the alternation operating is done.